

PA1800-68(Z)

68 pin PLCC socket/40 pin DIP 0.6" plug

Supported Device/Footprints

Using this adapter, the EP1810 in PLCC or CLCC package can be programmed on the EE Tools AllMax or Logical Devices ChipMaster 2000 & 3000 40 pin DIP programmers.

Device			Footprint	
Mfgr	Device	Package	Programmer	Plug
Altera	EP1810	68 PLCC, CLCC	AllMax & ChipMaster	40 pin DIP

Adapter Construction

The adapter is made up of 3 sub-assemblies. They assemble via connectors making the adapter modular. This way the sub-assemblies can be replaced when they wear out.

When disassembling the adapter take care not to bend the pins. When reassembling the adapter note the pin 1 indicators to align the parts correctly.

Test Socket

PLCC Auto-Eject test socket:

Yamaichi Part #: IC120-0684-304 LSC Part #: 68-304

Lidded ZIF test socket

Yamaichi Part #: IC51-0684-390 LSC Part #: 68-390

A1800-68, -Z

Accepts the test socket and performs the wiring in the Adapter Wiring section.

51BASE

Accepts the top board and provides the 40 pin DIP plug.

Adapter Parts & Part Numbers

The following chart shows the various socket and board part numbers that make up these adapters.

Adapter	Socket	TopBoard	Bottom Board
PA1800-68	68-304	A1800-68	51BASE
PA1800-68(Z)	68-390	A1800-68Z	51BASE

Adapter Dimensions

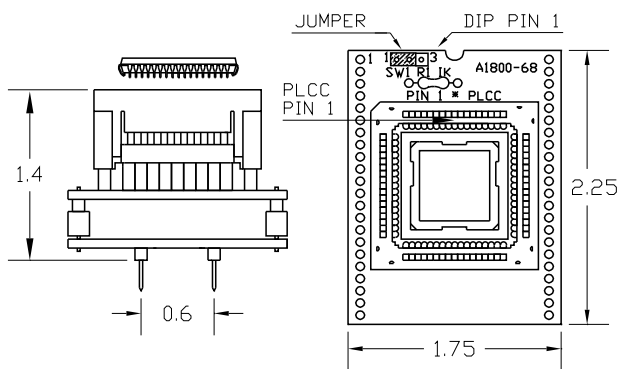

Press rim to open socket, Press device to close

PA1800-68

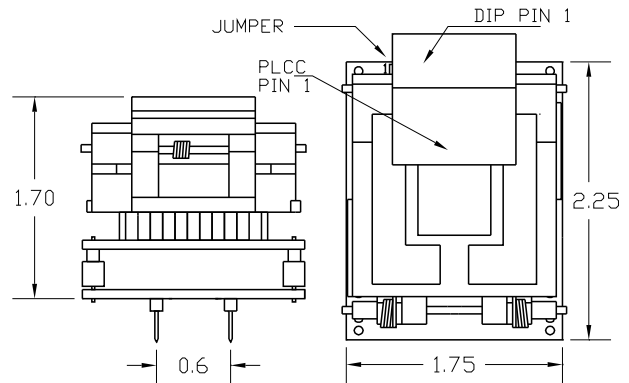

PA1800-68Z

Adapter Wiring

The following chart shows the connections from the PLCC device to the adapter's DIP plug.

DEVICE	PLUG	PLUG	DEVICE
1	20	25	68
2	24	26	67
3	23	27	66
4	22	29	65
5	21	-	64
6	-	-	63
7	-	-	62
8	-	-	61
9	-	31	60
10	31	10	59
11	10	18	58
12	-	17	57
13	-	16	56
14	-	15	55
15	-	14	54
16	-	-	53
17	4	34	52
18	34	-	51
19	1	13	50
20	9	9	49
21	32	32	48
22*	40 or 2	30	47
23	30	29	46
24	29	12	45
25	12	11	44
26	11	-	43
27	-	-	42
28	-	-	41
29	-	-	40
30	-	-	39
31	-	-	38
32	-	-	37
33	-	-	36
34	-	20	35

VCC to GND .1uf bypass, *Pin 22 connects to jumper SW1, and to a 1k pulldown resistor. See 'Jumper Settings' below.

Jumper Settings

Jumper pins 1-2 for the ChipMaster 3000.

Jumper pins 2-3 for the EETools AllMax & ChipMaster 2000.